

LONG NECK TYPE

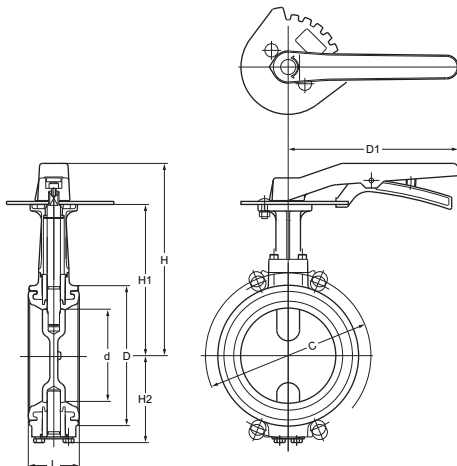

LONG NECK TYPE
 Prevented Dew Condensation

- A long stainless steel neck reduces conductivity of the fluid heat for prevention of dew condensation
- A availability of valve body and neck insulation.

Applications:

- Building utilities
- Piping networks for cold water, hot water and other water supply.

■ Dimensions

UNIT : MM

SIZE		d	H	H1	H2	L	D	C		D1
MM	INCH							10K	CLASS 150	
40	1½	40	174	130	60	33	78	105	-	180
50	2	50	176	132	66	43	93	120	120.5	180
65	2½	65	184	141	74	46	118	140	139.5	180
80	3	80	193	149	83	46	129	150	152.5	180
100	4	100	204	160	94	52	149	175	190.5	180
125	5	125	249	195	122	56	184	210	216	230
150	6	150	261	207	135	56	214	240	241.5	230
200	8	196	280	234	161	60	259	-	298.5	350

■ Cv Value

VALVE SIZE		PART NAME			
MM	INCH	30°	45°	60°	90°
40	1½	6	12	25	62
50	2	10	20	40	99
65	2½	15	37	80	205
80	3	26	77	132	372
100	4	50	127	260	723
125	5	93	212	419	1100
150	6	128	326	660	1820
200	8	194	501	1050	2780

■ Technical specification

CLASS		JIS 10K	CLASS 150
MAXIMUM SERVICE PRESSURE		1MPa	1MPa
SERVICE TEMPERATURE RANGE*1		-20°C~+120°C	
CONTINUOUS SERVICE TEMPERATURE RANGE		0°C~+100°C	
FACE-TO-FACE DIMENSION		API609,BS5155 (SHORT PATTERN) ISO 5752-20, JIS B 2002 46 SERIES	
SHELL TEST PRESSURE	[HYDROSTATIC]	1.5MPa	1.5MPa
SEAT TEST PRESSURE	[HYDROSTATIC]	1.1MPa	1.1MPa
COUPLING FLANGES		ASME CLASS 150 JIS B 2220 / 2239 10K	ASME CLASS 150 JIS B 2220 / 2239 10K

*1 CONDITION : FLUID IS NOT FROZEN.

■ Material

PARTS	MATERIAL
BODY	ALUMINUM DIE-CAST / EQUIVALENT ASTM B85-84-383.0
NECK	A351 GR. CF8
STEM	(EQUIVALENT ASTM A276 TYPE 410)
DISC	A351 GR. CF8M
O-RING	EPDM
RUBBER SEAT	EPDM
BOTTOM STEM	(EQUIVALENT ASTM A276 TYPE 410)
BEARING	POLYPHENYLENESULFIDE (SIZE 2" TO 8")

■ Valve Insulation

Areas in blue are recommended to insulate

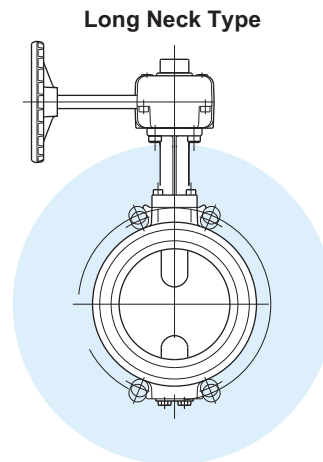

Choice of actuators for automated valve operation :

- Gear operated
- Pneumatically operated
- Electrically operated

-: MFG :-

VALSON VALVES CO.

AHMEDABAD - 2. (GUJ) INDIA.

VISIT US : WWW.VALSONVALVES.COM

